

USER'S GUIDE for  
**HAKITEC® 750**

**MONOPITCHED TEMPORARY ROOF with HAKI Trak Sheeting  
( Hand-Built )**



## INTRODUCTION

Temporary roof structures are by their very nature amongst the most difficult and demanding scaffolding assemblies.

Whilst HAKITEC750 provides a more efficient alternative to traditional equipment, HAKI believes that only trained and competent operatives should be allowed to erect the system.

Apart from installation of the equipment itself, a SYSTEM requires a SYSTEMISED approach to erection, which may be quite different to previous work methods.

Having the right number of operatives and designating specific work tasks is important to achieving efficiency.

### **Work at Height Regulations TG9:10 & SG4:10**

This Guide has been developed to meet the requirements of Work at Height Regulations (WAHR) and TG9:10 recommendations relating to Temporary Roof construction and SG4:10 Guidance on Prevention of Falls From All Temporary Works.



## **WARNING**



**ALL INFORMATION CONTAINED IN THIS MANUAL APPLIES ONLY TO COMPONENTS MANUFACTURED AND SUPPLIED BY HAKI.**

**ANY COMPONENTS ORIGINATING FROM OTHER SOURCES WHICH ARE INCORPORATED INTO A STRUCTURE WILL INVALIDATE THIS INFORMATION.**

**BY MIXING COMPONENTS OF OTHER MANUFACTURE THIS MAY INVALIDATE INSURANCE COVER.**

At HAKI, we continually strive for improvement and welcome constructive comments.

Date: April 2011

Subject to change

Customer is responsible to check for changes

## GENERAL DESCRIPTION OF SYSTEM

750mm deep Aluminium Alloy Beams laced together with modular Lacing Frames and Plan Braces

Beams are joined together using 2 Steel Connecting Tubes secured by 8 Spring Pins.

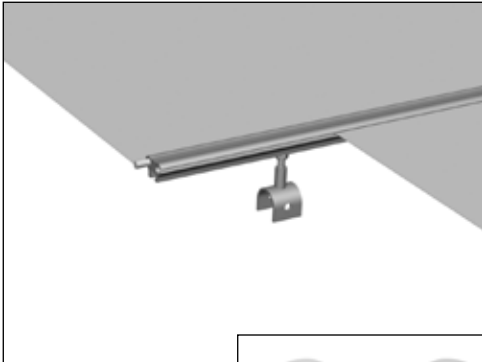
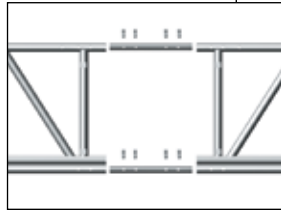
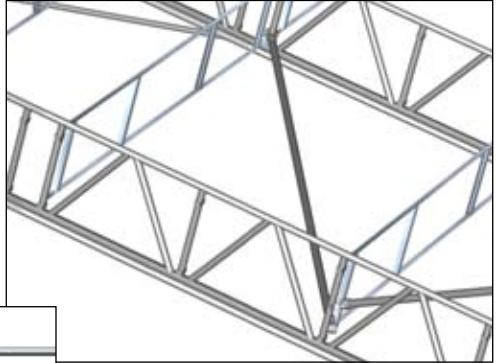

The HAKI Trak system consists of an aluminium alloy extruded track, with integral slots each side, fitted to the top chord of the HAKITEC750 beams with saddles secured by Spring Pins.

Joints in the HAKI Trak units are made using Joiners & Seals and are secured with Joint Plates.

Sheeting is then pulled through the integral slots forming weather resistant roof covering.



## GENERAL PRINCIPLES

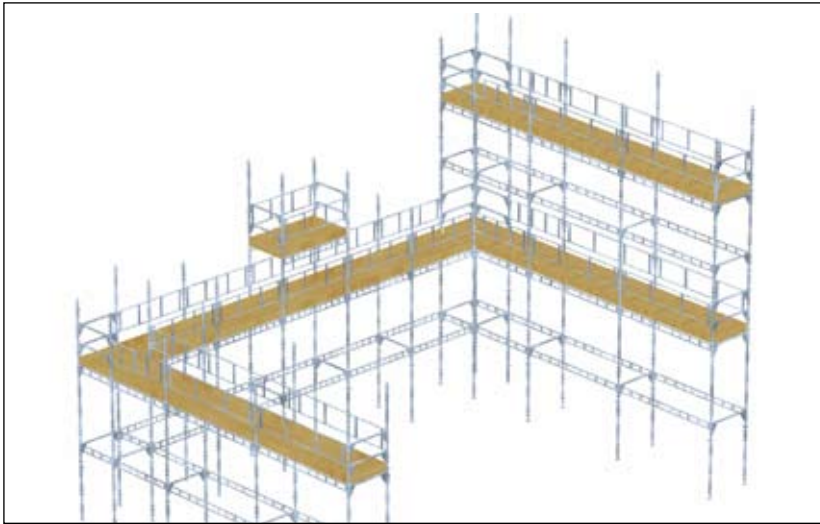

The temporary roof and supporting structure should be designed by a competent engineer who has considered all appropriate aspects of the roof erection.

All materials are at the work place ready for erection.

The correct number of trained operatives is available. All necessary PPE is available and utilised. All necessary tools are available.

Whenever any operative cannot work from fully guarded platform, he will attach his own lanyard to the HAKITEC750 Beam (preferably top chord) or the running line when it is safe to do so.

One complete set of Walk Boards is available for access to the structure being erected.







Side scaffold, in accordance with design drawing, should be ready to receive roof structure.





Note: it is recommended that a boarded platform is provided at a level approximately 1 metre below the bottom chord of the truss where it meets the outside standards.







End scaffold should be provided, fully guardrailed on all faces and with adequate access.







If end scaffold is not provided, a suitable access platform should be erected from the existing roof to facilitate this erection procedure.

## COMPONENTS



	DESCRIPTION	SIZE	ITEM No.	WEIGHT kg
	FRAME 750 / AL	6.25m	4032625	44.7
	FRAME 750 / AL	3.25m	4032325	23.9
	FRAME 750 / AL	2.25m	4032225	16.6
	FRAME 750 / AL	1.25m	4032125	9.4
	CONNECTOR TUBE 750 G		7203001	2.0
	SPRING PIN 12mm		2113100	0.1
	SINGLE GUARDRAIL	3.05m 2.5m 1.655m	8722300 8722250 8722160	11.00 9.2 6.4

	DESCRIPTION	ITEM No.	WEIGHT kg
	LACING FRAME		
	3.05m	7052301	11.4
	2.5m	7052246	9.6
	1.655m	7052161	7.8
	1.25m	7052121	6.0
	BEAM ADAPTOR 750 G	7203325	16.8
	BEAM ADAPTOR CLAMP	5231616	2.0
	GUARDRAIL POST 750	7203322	10.3
	PLAN BRACE		
	3.05 x 2.25m (L=3.79m) Red	7503022	6.0
	3.05 x 2.0m (L=3.647m) Blue	7503020	5.8
	2.5 x 2.25m (L=3.363m) Green	7502522	5.3
	2.5 x 2.0m (L=3.202m) Gold	7502520	5.1
	1.655 x 2.25m (L=2.793m) Pink	7501622	4.4
	1.655 x 2.0m (L=2.596m) Orange	7501620	4.2
	1.25 x 2.25m (L=2.574m) Black	7502126	4.1
1.25 x 2.0m (L=2.358) Brown	7502125	3.8	

	DESCRIPTION	ITEM No.	WEIGHT kg
	HAKI Trak 6.25m 3.25m 2.25m 1.25m	7541625 7541325 7541225 7541125	12.9 6.7 4.7 2.6
	HAKI Trak END TRACK 15 <sup>a</sup> 22.5 <sup>a</sup>	7541150 7541220	3.3 3.3
	HAKI Trak CLAMPS SADDLE TYPE COUPLER TYPE	7541000 7541001	0.5 1.0
	END BRACKET	7541002	1.25
	HAKITRAK JOINER	7540001	0.035
	HAKITRAK SEAL	7540002	
	HAKITRAK JOINT PLATE	7540000	0.16



	DESCRIPTION	ITEM No.	WEIGHT kg
	750 ERECTION BRACKET	UK7500025	4.8
	WALK BOARD ERECTING HOOK	UK4052002	1.8
	750 WALKING BOARD	7500004	14.5
	2m	7500005	16.3
	2.25m		
	HAKI Trak SHEETING BAR	7500006	6.8
	3.05m	7500007	5.5
	2.5m	7500026	3.6
	1.655m	7500012	2.7
	1.25m		
	HAKI Trak PULLING DEVICE	7500008	8.0
	3.05m	7500009	7.0
	2.5m	7500028	6.0
	1.655m	7500011	5.0
	1.25m		
	HAKI Trak EAVES ROLLER BRACKET	7500010	7.4

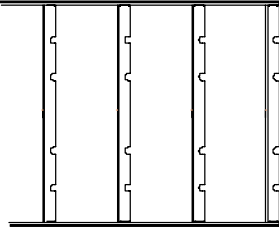
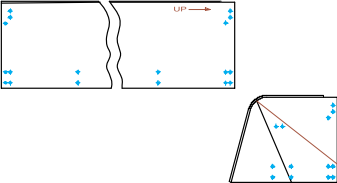







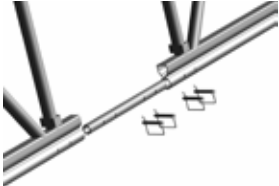
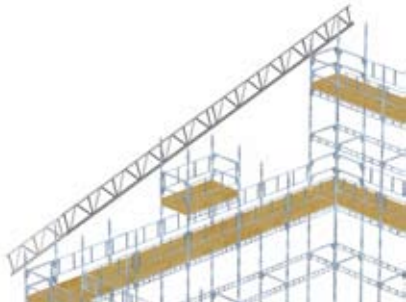

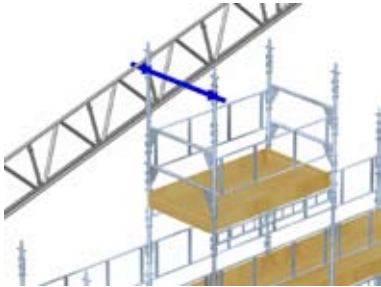
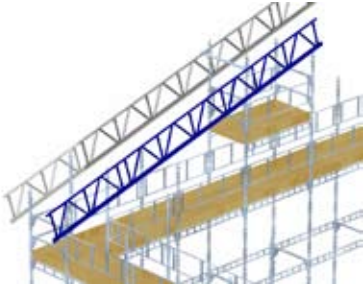
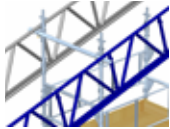
	DESCRIPTION	ITEM No.	WEIGHT kg
	HAKI Trak TENSION BAR		
	3.05m	7500015	6.2
	2.5m	7500014	4.8
	1.655m	7500027	3.3
	HAKI Trak TENSION TUBE		
	3.05m	7500022	13.3
	2.5m	7500023	9.2
	1.655m	7500029	5.9
	RATCHET FIXING STRAP	7540003	0.5
	HAKI Trak SHEETING	7542###	0.7kg/sqm
	HAKI Trak PELMET SHEETING		
	6.25m	7542104	4.4
	3.25m	7542103	2.3
	2.25m	7542102	1.6
	1.25m	7542101	1.0
	END	7542106	1.0

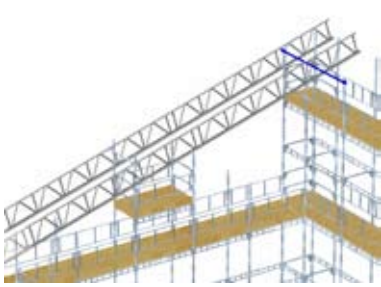
## MONOPITCHED TEMPORARY ROOF ERECTION METHOD

### ASSEMBLY OF FRAMEWORK

1		<p><b>TRUSS 1</b> Position 1st beam on inside guardrail/ledger (or Beam Adaptor, depending on design) at lower supporting scaffold and secure in position by a temporary fixing to a standard/puncheon on the table lift.</p> 
2		<p>Add additional beams to complete Truss 1.</p> <p>Beams are joined end-to-end with Connector Tubes (2 per joint) and retained with Spring Pins (8 per joint).</p> 
3		<p>Connect the completed truss to the upper side scaffold as specified by the design drawing.</p> <p>Remove the temporary fixing from the table lift.</p> <p>Connect truss to the lower side scaffold as specified by the design drawing.</p>



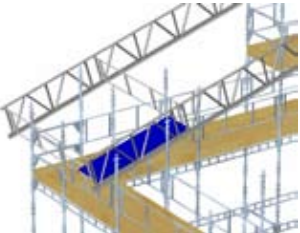



4		<p>Fit temporary needle to table lift below the top chord of the beam.</p>
5		<p><b>TRUSS 2</b> Position 1st beam on inside guardrail/ledger (or Beam Adaptor, depending on design) at the table lift. This will prevent the beam from sliding down during the next stages of the procedure.</p> 
6		<p>Add additional beams to complete Truss 2</p>
7		<p>Fit a temporary tube (at least 3,5m long) to the upper side scaffold positioned under the top chord of the 750 Beam.</p> <p>This will prevent the beam from the sliding down during the next stage of the procedure.</p>





8	 	<p>From the table lift, fit a temporary single Guardrail into a pocket of Truss 2. With a minimum of 3 operatives, the operative at the table lift will control the truss with the single guardrail while the other operatives "walk out" the complete truss.</p>
9		<p>When the truss is at its final position, fit the single Guardrail into the corresponding pocket of Truss 1. This will give the correct spacing for the truss. (This will be replaced by a Lacing Frame at a later stage)</p> 
10		<p>From the safety of the side scaffold, fit lacing frame at bottom end of bay, and two frames at top end (2m / 2.25m apart). These will give the correct spacing of the truss. Fit a pair of crossing Plan Braces at one end. These will ensure that the bay is square. Connect the completed truss to both side scaffolds as specified by the design drawing. The plan Braces should then be removed. (Note: one will be replaced at a later stage).</p>
11		<p>From the safety of the side scaffold, fit next Lacing Frame at lower end of the bay.</p>
12		<p>Place 1st Walk Board on to bottom tubes of Lacing Frames.</p>



**As Specified By TG9:10 & SG4:10**

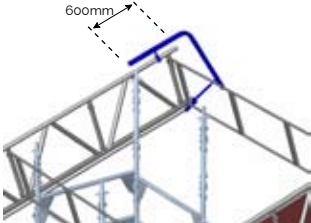

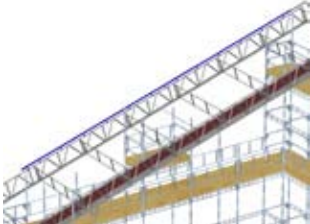
For operative feeding materials (feeder) to operatives working on beams (climbers), it is necessary to progressively place Walk Boards on bottom chords of lacing frames adjacent to truss line. The feeders will attach a Fixed Lanyard to the adjustable Running Line fixed to the top chord of the Truss.

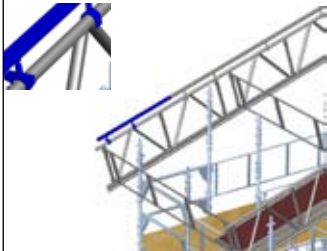
13		<p>Whilst clipped on to the Beam, the feeder attaches the fixed end of the Running Line to the top of the end vertical member.</p> <div style="border: 1px solid black; padding: 5px; text-align: center;"> <p><b>Clips must NEVER be attached to Lacing Frames</b></p> </div>
14		<p>The Climber proceeds to the 2nd Lacing Frame position, and attaches the progressive end of the Running Line to the top of the nearest vertical stiffener behind him.</p>
15		<p>The Feeder now fully tensions the Running Line.</p>
16		<p>By attaching his lanyard to the Running Line, the Feeder can now carry the next Lacing Frame and pass it to the Climber.</p>
17		<p>The second Walking Board is now fitted using erection hook. The Feeder then returns to the eaves and attaches his lanyard to the Beam, releasing tension on the Running Line (in accordance with the manufacturer's instructions). The Climber moves to his next lacing frame position taking the progressive end of running line with him and re-attaches. Then the line is re-tensioned.</p>
18		<p>Stages 14 to 15 are repeated for the remaining Walk Boards and lacing frames. Single Guardrail replaced with Lacing Frame.</p>

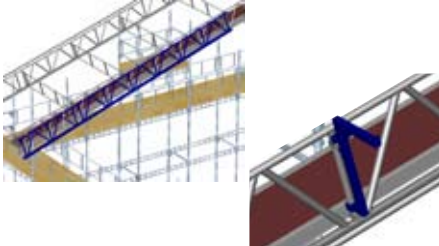
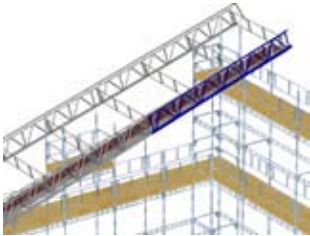
19		<p>Slide Saddle Clamps into HAKI Trak sections and finger tighten the nuts.</p> <p>At Truss 1 at top, fit HAKI Trak End Track 600mm from End of beam and secure the Saddle Clamp with a Spring Pin. Adjust and fit the End Bracket with a Spring Pin through the bottom chord of the Beam.</p>
20		<p>Prepare next HAKI Trak section by adding Joint Plate, Joiner and Seal.</p>
21		<p>Working from the top of the Truss, fit remaining HAKI Trak sections to Truss 1 working from the end scaffold.</p> <p>With the exception of the lowest beam in each truss, the HAKI Trak sizes will match the beam size.</p>
22		<p>At the lowest beam section, the Trak will be shorter than the beam length.</p> <p>For a 2.25m beam, use 1.25m Trak. For a 3.25m beam, use 2.25m Trak. For a 6.25m beam, use 3.25m and 2.25m Traks.</p>
23		<p>The lowest Trak section will require a Coupler Type Clamp at its lowest end.</p> <p>Ensure when designed, the end of trak is well over the inside leg of supporting scaffold. To ensure sheeting covers scaffold.</p>

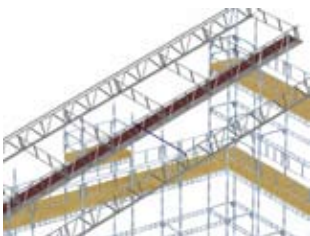
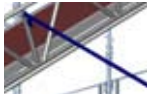
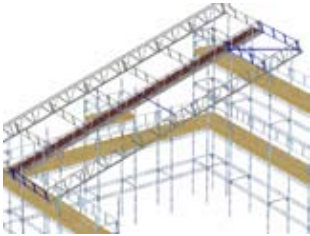
24		<p><b>TRUSS 3</b></p> <p>The Climber will now work from previously erected Walk Board at approximately half-way along Truss 2.</p> <p>The erection bracket is connected to a vertical member for the next truss to rest upon during connection sequence.</p>
25		<p>Assemble rest of truss in similar manner to Stages 5 to 7.</p>
26		<p>Climbing operative will fit Single Guardrail into a pocket of Truss 3.</p>
27		<p>With operatives at each side, "walk out" the complete truss. The operative on Truss 2 will control the truss.</p> <p>When Truss 3 is at the correct position, the Single Guardrail is fitted into the top pocket of Truss 2. <b>(This will be replaced by a Lacing Frame at a later stage)</b></p> 
28		<p>Erection Bracket should now be removed until it is next required.</p> <p>Lacing &amp; Bracing to square is then fitted as Stages 9 to 10.</p> <p>Connect the completed truss to both side scaffolds as specified by the design drawing.</p> <p>(Note: the Single GuardRail should be removed until it is required for the next bay.</p>

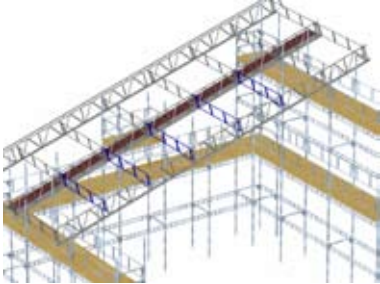
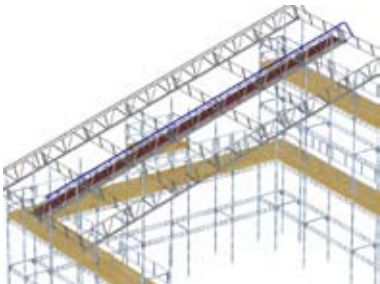
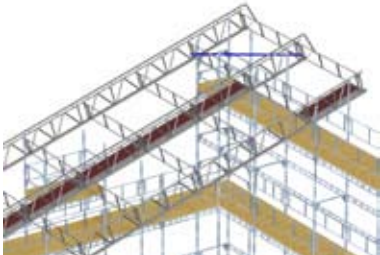
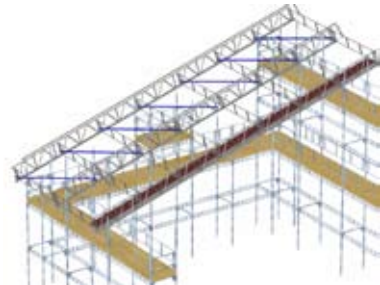
29		<p>Remove the Plan Brace for movement of deck and fit remainder of Lacing.</p>
30		<p><b>HAKEI TRAK TRUSS 2</b> Stages 19 to 23 are repeated.</p>
31		<p>Move Walk Boards. Fit Plan Brace behind.</p> <p>Generally, Plan Bracing is fitted in end bays, then at 1 bay in 5 between (refer to design drawing)</p>
32		<p>Repeat for complete bay.</p> <p>Repeat Stages 24 to 32 for the entire length of the roof.</p> <p>Finally, remove Walk Boards.</p>





## SHEETING

### IMPORTANT

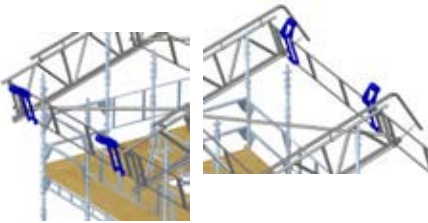
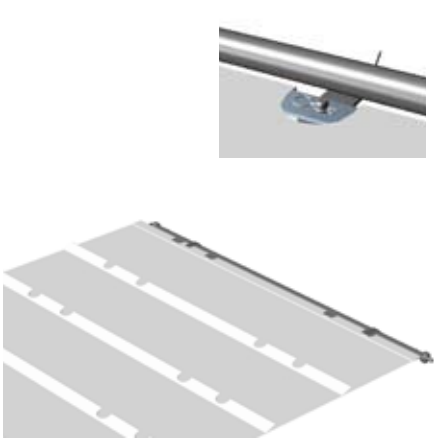
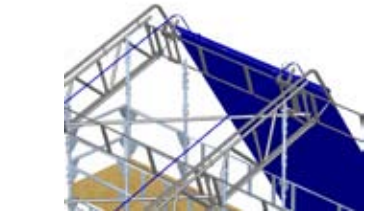
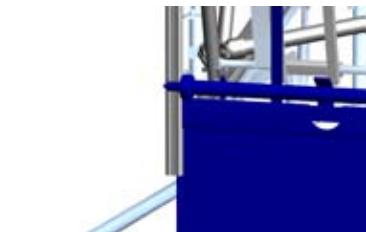
Prior to sheeting, ensure that any additional equipment to fully comply with the design drawing is installed. eg., Knee Braces, Anchors, Counterweights etc.

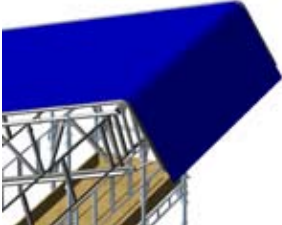
33		<p>Fit a pair of Eaves Roller Brackets to the last lacing frame at either end of bay.</p> <p>Arrange for a pair of ropes (of sufficient length) to be laid over the complete bay of roof.</p>
34		<p>Position sheet at Upper Side of roof.</p> <p>Thread Sheetting Bar through sheet pocket and attach to Pulling Device with the R-Clips.</p> <p>Attach ropes to pulling device and take up slack (from Lower end of roof)</p>
35a		<p>As ropes gently pulled, locate wheels of Pulling Device and feed end of sheet into open end of track.</p>
35b		

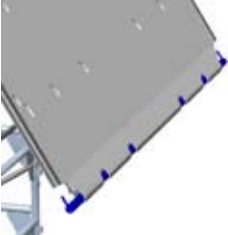
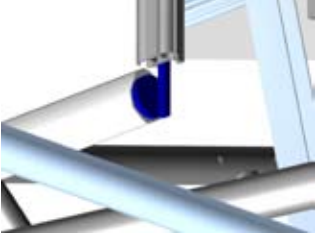
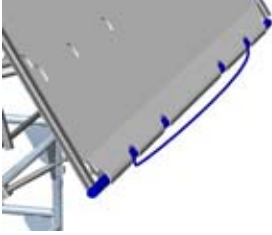
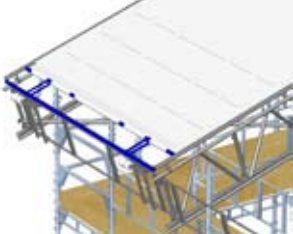
36		<p>Continue to pull sheet until only 100 to 300mm of sheet remains outside track at Upper Side of roof.</p>
37		<p>Remove Eaves Roller Brackets from Upper Side.</p>
38		<p>At Upper Side of roof: Fit Tension Bar through sheet pocket. Pull sheet such that Tension Bar locates into end of tracks. Fit ratchet strap between loops on Tension Bar to retain inside the sheet pocket.</p>
38a		<p>38b</p> 
39		<p>At lower Side of roof: Remove Pulling Device and Sheeting Bar. Thread Tension Tube through sheet pocket. Fit Ratchet Straps around Tension Tube AND loops of Tension Bar. Locate Tension Bar in end of track. Tension the sheet to close the gap between Tension Tube and Tension Bar.</p> <p>(Note: It is important that the sheet is fully tightened).</p>

## SHEET INFORMATION

### Pelmets

Fit End Pelmet and fix to Frame vertical using Cable Tie (or similar).

Slide next full pelmet sheet with cut-out edge uppermost.

Mate pelmets together so that overlapping flap is downward. Fix through common eyelets using Cable Ties (or similar). Repeat for all pelmet sheets along side of gable.

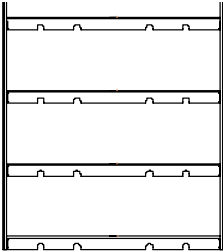
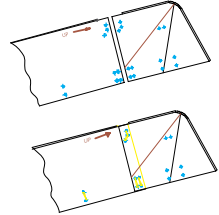

### HAKI Trak Sheet

Base fabric: polyester

Coating: flexible pvc both sides

Weight: 610gms/sq.m

Temperature resistance: - 20°C

Flame Retardant to BS.5438 2A  
(No flame or after glow)

## TECHNICAL INFORMATION

### 750 Beam

Mean Weight = 7.5 kg/m

Permissible Bending Moment = 41.3 kN.m  
(Ultimate = 68 kN.m)

Permissible Shear Force = 30.6kN  
(Ultimate = 50 kN)

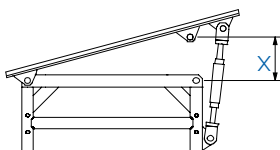
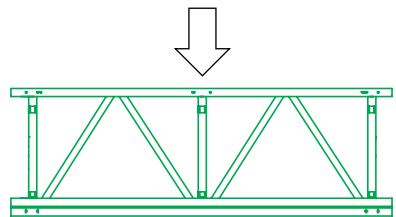

### Beam Adaptor

for 15°  
X = 180mm

for 22.5°  
X = 255mm

### HAKI Trak

Weight = 2.1 kg/m

Permissible Bending Moment = 1.33 kN.m  
0.93 kN.m at joint

Permissible Concentrated Load = 13 kN



## HAKI Experience

With over 50 years experience to call on, HAKI has gained a leading reputation in its field. With its own R & D and manufacturing facilities, the company now operates throughout Europe and its equipment is in use worldwide. With all products designed and manufactured to BS EN 12810 and a quality system to BS EN ISO 9001:2000 coupled with a comprehensive training and support infrastructure, you can rely on HAKI for support.

## HAKI Training

The Company's dedicated Centre of Excellence Training Centre is equipped with the full range of HAKI products where a comprehensive choice of courses is offered. With the benefit of this training, all users of HAKI products can be assured that the equipment is being employed safely and effectively.

## HAKI Support

From computerised estimating facilities to on site assessment and project back up, HAKI is with its customers every step of the way. Working with HAKI means far more than just proven equipment, it means working with people who understand the scaffolding industry. Whatever the project, the company is committed to ensuring every user enjoys the full benefits associated with the use of HAKI - maximising time savings, safely, profitably, and above all, SAFETY.

## HAKI Safety Checklist

1. Have you got a copy of the design drawing for the Temporary Roof?
2. Is the scaffold/supporting structure completed ready for the temporary roof?
3. Is the ground condition adequate to take the load imposed?
4. Is the correct equipment on site?
5. Is the correct equipment in good working order?
6. Is the correct personal Protection Equipment available and in good working order with rescue procedure in place?
7. Are all the components in their correct position and all locking catches engaged?
8. Have you considered?
  - Number of erectors
  - Designated tasks
  - Starting position for erection
  - Distribution of equipment



**SPECIALISTS IN SCAFFOLDING AND WEATHER PROTECTION SYSTEMS**

**HAKI Ltd.** Magnus, Tame Valley Industrial Estate, Tamworth, Staffordshire B77 5BY UK

**Phone:** +44 (0)1827 282000 **Fax:** +44 (0)1827 285400

Email: [info@haki.co.uk](mailto:info@haki.co.uk) Web: [www.haki.co.uk](http://www.haki.co.uk)